

F.T.M.C . Three Phase MCB Dimensions Boards Accessories

Flush Type

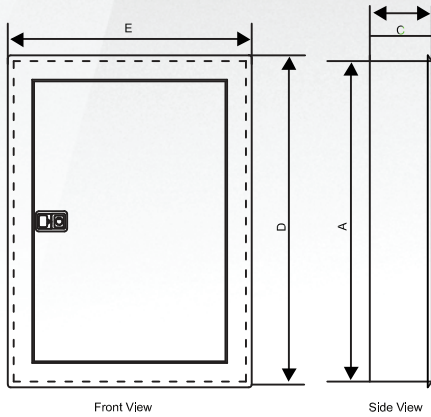

Surface Type

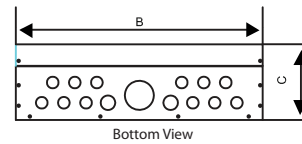
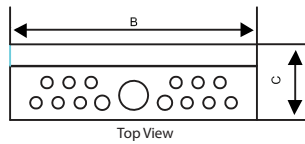
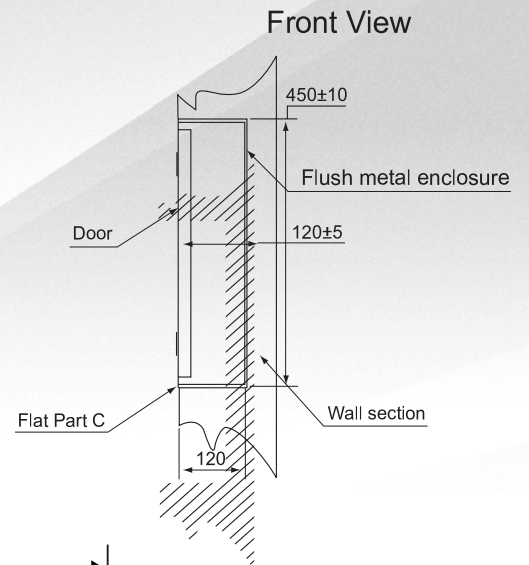
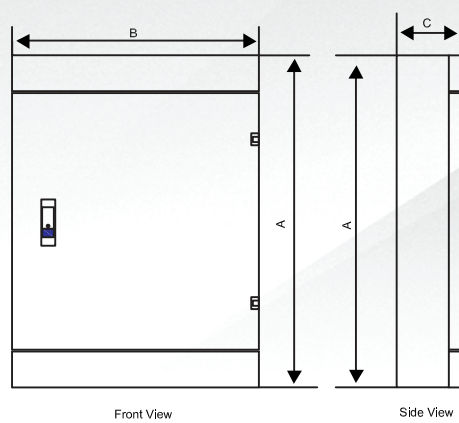

Dimensions(mm)

Maximum cable capacity

Incomer and feeders

- Neutral bar 10mm²
- Earth bar 10mm²
- MCB 25mm²
- RCD 63Amp-25mm², 80&100Amp-50mm²
- RCBO 16mm²
- Switch disconnectors 125Amp-35mm²
- Direct cable Without incomer kit 35mm²
With incomer kit 150mm²

"FTCG"&"FTCF" frame MCCB

- Without external box 100Amp-2.5 to 50mm², 225Amp-25 to 70mm²
- Without external box 225Amp-95mm²

"FTCJ" frame MCCB

- Without external box 25 to 70mm²
- Without external box 25 to 185mm²

F.T.M.C . Three Phase MCB Dimensions Boards Accessories

- To be used for additional cable space.
- To be used for the installation of additional control, metering or power components.
- 1.2mm sheet steel thickness.
- Epoxy powder paint finish RAL 7032.
- Easy to install.
- Removable front & bottom plate for direct access.

Extension Boxes for MCB/RCCB(Top&Bottom)

Part No.	Ref. No.	Height (mm)	Width (mm)	Depth (mm)
FTCEXB105/200	F101893	200	430	105
FTCEXB105/400	F101894	400	430	105
FTCEXB120/200	F101895	200	430	120
FTCEXB120/400	F101896	400	430	120

Extension Boxes for MCCB(Top&Bottom)

Part No.	Ref. No.	Height (mm)	Width (mm)	Depth (mm)
FTCEXB135/200	F101897	200	430	135
FTCEXB135/400	F101898	400	430	135

Blanking Plates Accessories

Blanking plates are used to cover any space ways

Part No.	Ref. No.	Description
FTCBPMCB	F101899	Blank plate for 1 pole MCB breakers
FTCBPFTCG	F101900	BlankPlateforMCCB(FTCG)Breakers
FTCBPFTCF	F101901	BlankPlateforMCCB(FTCF)Breakers